



# Underfloor Ducting Systems

**Ega**



# Ega Underfloor Ducting System

## Introduction

The EGA Underfloor Ducting System is designed to enclose power, telephone and ancillary system service cables, facilitating distribution in commercial and other similar establishments.

Current commercial environments require multiple electrical circuitry for secretarial, accounting and complex communication facilities. Open plan office layouts and modern building methods need a versatile arrangement of services for easy installation and flexibility in use.

The EGA Underfloor Ducting System is a solution for such cable management needs.

The system comprises four basic groups of equipment which can be used together to provide the desired underfloor configuration: underfloor ductings, service outlet boxes, junction boxes and vertical access units.

Facilities for wiring accessories to British Standard are offered although the outlet boxes can be adapted to accommodate either European or American accessories.

The system is intended for laying on the structural slab prior to the screed being poured. Screeding levels of between 55mm and 90mm can be accommodated and a minimum screed cover of 25mm is recommended over the ducting.

All junction and service boxes in the EGA Underfloor Ducting Systems are manufactured from high pressure zinc alloy die-casting materials for strength and durability. Disposable casting lids are also supplied with all boxes. The trap cover for the service boxes are retained by hinges and grommets are supplied to prevent cable damage at exit positions.

## Authority

EGA products enable full compliance with the requirements of the current IEE regulations.

## Important Note

Where 55mm deep boxes are utilized, it is desirable to use slim pattern accessory plugs, with a maximum projection of 22mm to ensure that the box lid will close flat when the services are in use.

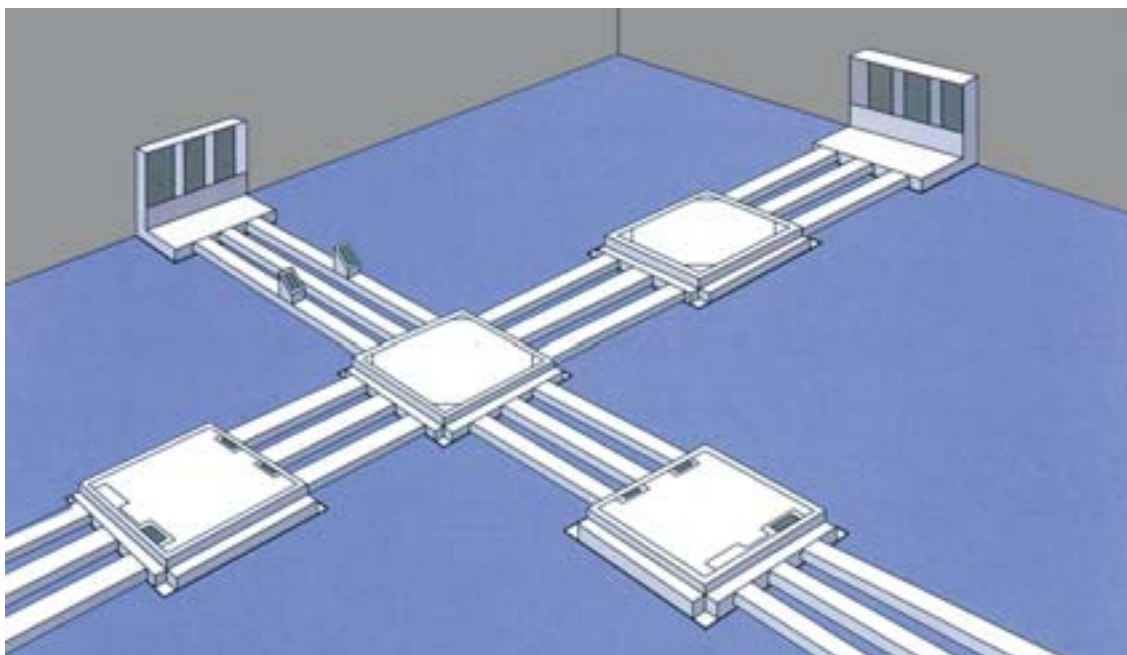

# Contents



P A G E

- Planning and Layout 3
- UPVC Ducting and Accessories 4
- Metal Ducting and Accessories 5
- Junction Box 7
- Service Outlet Box 9
- Service Outlet Box Accessories 11
- Vertical Access Boxes 13
- Pedestal Outlet Boxes 13
- Specifier's Guide 14
- Installation Guide 15

# Planning and Layout

## Planning and Layout

Two parameters must be known before starting to design the system. Depending on the services to be installed, (1) whether a two or three duct system is required and (2) the depth of screed into which the system is to be installed. The minimum screed depth for EGA Underfloor Ducting System is 55mm.

## Layout

In order that the installation may exhibit the desired flexibility, the ducting is usually laid out on a Grid, Fishbone or Comb Pattern of single, double or triple runs.

A Grid Pattern is widely used in areas where the occupants require a good degree of flexibility in reorganising work areas. Capacity can be increased by returning individual ring mains through different runs of ducting which in itself makes for easier installation.

The Fishbone Pattern is ideal for a medium size area where lesser boxes are required.

The Comb Pattern is the most economical way of installation wherein less ducting is used. It offers an extremely cost effective solution.

## Planning

In designing the Underfloor Ducting System, it is essential to take into account the following:

- Introduction of ducting begins at the distribution board of the floor concerned.
- Determine the services, capacity of ducting and the junction boxes to be laid.
- Ducting should be laid onto level of structural slab and it requires minimum 25mm screed to cover the ducting.
- In long runs of ducting, access should be provided by using junction boxes as draw-in boxes. It is recommended that the distance between two junction boxes must not exceed 6 metres.
- The extent to which a service outlet box can be equipped with facilities is limited by its dimensions. Our standard service outlet boxes are designed to meet the requirements of a normal workplace.
- We recommend the use of carpeting with a backing of at least 2mm thick.
- Our protective edges for covers and carpets will withstand chairs fitted with castors.
- We recommend that duct outlets be incorporated along walkways. This will provide greater flexibility for future services requirements with the use of pedestal outlet boxes mounted on top.

A typical Fishbone Pattern

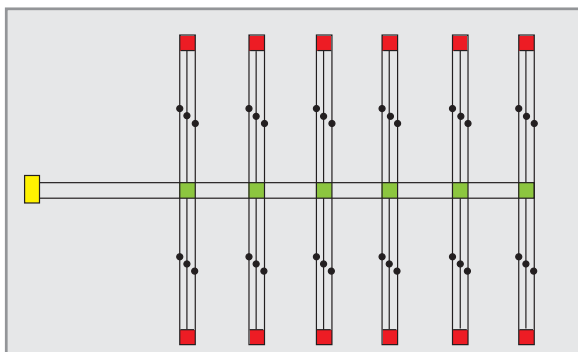

A typical Comb Pattern

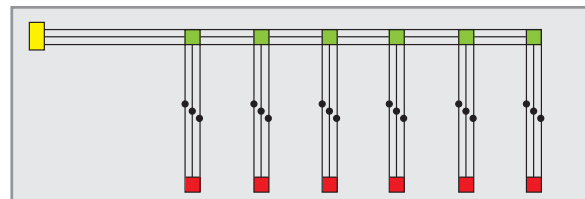

A typical Grid Pattern

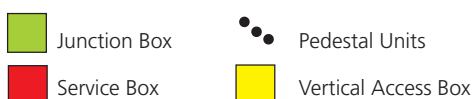
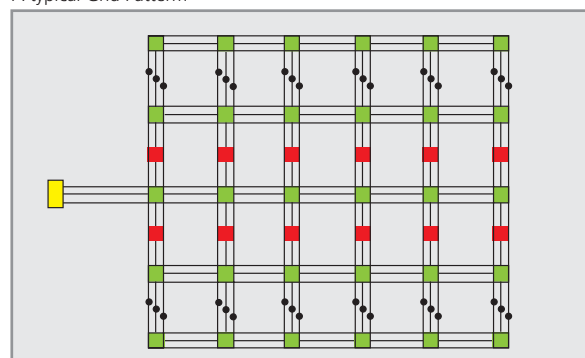

# UPVC Ducting and Accessories

- Material : Heavy gauge super high impact uPVC
- Standard length : 2.9 metres
- Standard pack : 29 metres
- Pre-cut lengths can be arranged, subject to price confirmation and availability

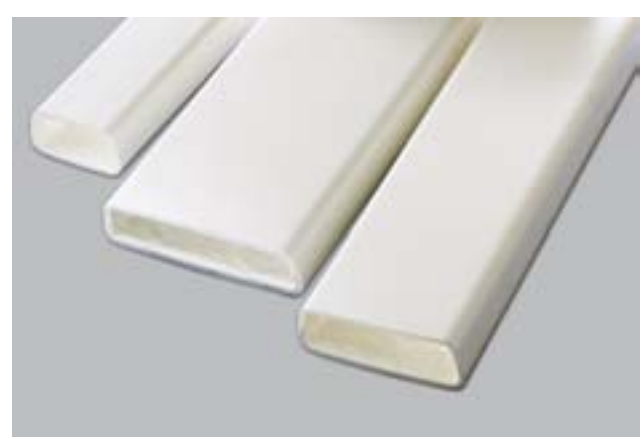

### uPVC Ducting

List No.	Description
UFD 125 W	50 x 25 x 2.5mm
UFD 232 W	75 x 25 x 3.2mm
UFD 332 W	100 x 25 x 3.2mm



### Jointing Sleeve

List No.	Description
UJ 125 W	50 x 25 x 2.5mm
UJ 232 W	75 x 25 x 2.5mm
UJ 332 W	100 x 25 x 2.5mm

CROSS SECTION AREA (mm <sup>2</sup> ) OF CABLE	NUMBER OF CABLES		
	UFD 125 W	UFD 232 W	UFD 332 W
1.5	34	52	73
2.5	27	42	58
4	18	29	40
6	14	22	31
10	10	15	20
16	6	10	14

The table above indicates the cable carrying capacity of EGA UFD duct systems, based on a 35% utilisation factor (as required) by the IEE Regulations using PVC-insulated multi strands cables to BS 6004 : 1969.

# Metal Ducting and Accessories

- Material : Pre-galvanized sheet steel
- Standard thickness : 1.6mm
- Standard lengths : 2.44 metres
- Single, twin or triple compartments
- Standard depths : 25mm, 32mm and 38mm
- Coupler has to be ordered separately
- Pre-cut lengths can be arranged, subject to price confirmation and availability
- Pre-punched duct outlet holes can also be arranged on order

## Metal Ducting

List No.	Description
UMD 50/1/6	50 x 25 x 1.6mm 1 compartment
UMD 75/1/6	75 x 25 x 1.6mm 1 compartment
UMD 100/1/6	100 x 25 x 1.6mm 1 compartment
UMD 100/2/6	100 x 25 x 1.6mm 2 compartments
UMD 150/2/6	150 x 25 x 1.6mm 2 compartments
UMD 150/3/6	150 x 25 x 1.6mm 3 compartments
UMD 200/2/6	200 x 25 x 1.6mm 2 compartments
UMD 225/3/6	225 x 25 x 1.6mm 3 compartments
UMD 275/2/6	275 x 25 x 1.6mm 2 compartments
UMD 275/3/6	275 x 25 x 1.6mm 3 compartments
UMD 300/3/6	300 x 25 x 1.6mm 3 compartments
UMD 375/3/6	375 x 25 x 1.6mm 3 compartments



List No.	Description
UMDH 50/1/6	50 x 32 x 1.6mm 1 compartment
UMDH 75/1/6	75 x 32 x 1.6mm 1 compartment
UMDH 100/1/6	100 x 32 x 1.6mm 1 compartment
UMDH 100/2/6	100 x 32 x 1.6mm 2 compartments
UMDH 150/2/6	150 x 32 x 1.6mm 2 compartments
UMDH 150/3/6	150 x 32 x 1.6mm 3 compartments
UMDH 200/2/6	200 x 32 x 1.6mm 2 compartments
UMDH 225/3/6	225 x 32 x 1.6mm 3 compartments
UMDH 275/2/6	275 x 32 x 1.6mm 2 compartments
UMDH 275/3/6	275 x 32 x 1.6mm 3 compartments
UMDH 300/3/6	300 x 32 x 1.6mm 3 compartments
UMDH 375/3/6	375 x 32 x 1.6mm 3 compartments



List No.	Description
UMDX 50/1/6	50 x 38 x 1.6mm 1 compartment
UMDX 75/1/6	75 x 38 x 1.6mm 1 compartment
UMDX 100/1/6	100 x 38 x 1.6mm 1 compartment
UMDX 100/2/6	100 x 38 x 1.6mm 2 compartments
UMDX 150/2/6	150 x 38 x 1.6mm 2 compartments
UMDX 150/3/6	150 x 38 x 1.6mm 3 compartments
UMDX 200/2/6	200 x 38 x 1.6mm 2 compartments
UMDX 225/3/6	225 x 38 x 1.6mm 3 compartments
UMDX 275/2/6	275 x 38 x 1.6mm 2 compartments
UMDX 275/3/6	275 x 38 x 1.6mm 3 compartments
UMDX 300/3/6	300 x 38 x 1.6mm 3 compartments
UMDX 375/3/6	375 x 38 x 1.6mm 3 compartments



### Fixing Clip (Pre-Galvanised Steel Sheet 1.2mm Thickness)

List No.	To Suit Ducts
UFC 150	1 no. UMD 50/1/6
UFC 250	2 nos UMD 50/1/6
UFC 350	3 nos UMD 50/1/6
UFC 175	1 no. UMD 75/1/6
UFC 275	2 nos UMD 75/1/6
UFC 375	3 nos UMD 75/1/6
UFC 1100	1 no. UMD 100/1/6 or 1 no. UMD 100/2/6
UFC 2100	2 nos UMD 100/1/6
UFC 3100	3 nos UMD 100/1/6
UFC 1150	1 no. UMD 150/2/6 or 1 no. UMD 150/3/6
UFC 1200	1 no. UMD 200/2/6
UFC 1225	1 no. UMD 225/3/6
UFC 1275	1 no. UMD 275/2/6 or 1 no. UMD 275/3/6
UFC 1300	1 no. UMD 300/3/6
UFC 1375	1 no. UMD 375/3/6

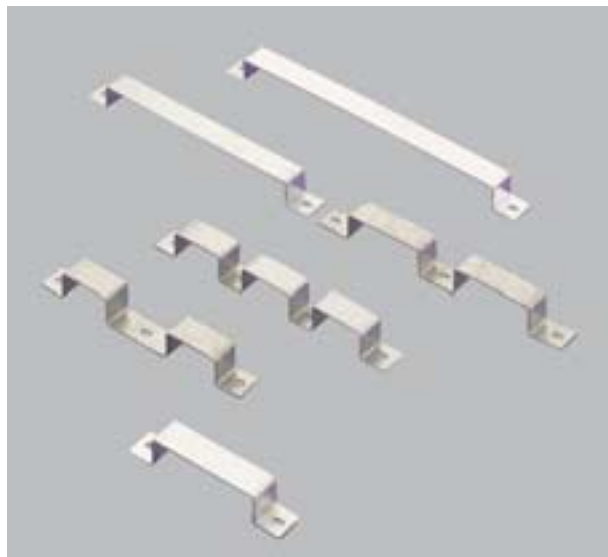

List No.	To Suit Ducts
UFCH 150	1 no. UMDH 50/1/6
UFCH 250	2 nos UMDH 50/1/6
UFCH 350	3 nos UMDH 50/1/6
UFCH 175	1 no. UMDH 75/1/6
UFCH 275	2 nos UMDH 75/1/6
UFCH 375	3 nos UMDH 75/1/6
UFCH 1100	1 no. UMDH 100/1/6 or 1 no. UMDH 100/2/6
UFCH 2100	2 nos UMDH 100/1/6
UFCH 3100	3 nos UMDH 100/1/6
UFCH 1150	1 no. UMDH 150/2/6 or 1 no. UMDH 150/3/6
UFCH 1200	1 no. UMDH 200/2/6
UFCH 1225	1 no. UMDH 225/3/6
UFCH 1275	1 no. UMDH 275/2/6 or 1 no. UMDH 275/3/6
UFCH 1300	1 no. UMDH 300/3/6
UFCH 1375	1 no. UMDH 375/3/6

List No.	To Suit Ducts
UFCX 150	1 no. UMDX 50/1/6
UFCX 250	2 nos UMDX 50/1/6
UFCX 350	3 nos UMDX 50/1/6
UFCX 175	1 no. UMDX 75/1/6
UFCX 275	2 nos UMDX 75/1/6
UFCX 375	3 nos UMDX 75/1/6
UFCX 1100	1 no. UMDX 100/1/6 or 1 no. UMDX 100/2/6
UFCX 2100	2 nos UMDX 100/1/6
UFCX 3100	3 nos UMDX 100/1/6
UFCX 1150	1 no. UMDX 150/2/6 or 1 no. UMDX 150/3/6
UFCX 1200	1 no. UMDX 200/2/6
UFCX 1225	1 no. UMDX 225/3/6
UFCX 1250	1 no. UMDX 250/3/6
UFCX 1275	1 no. UMDX 275/2/6 or 1 no. UMDX 275/3/6
UFCX 1300	1 no. UMDX 300/3/6
UFCX 1375	1 no. UMDX 375/3/6

### Duct Outlet

(List No. UDO 125)

Duct outlets are used to connect ducting and pedestal outlets. EGA duct outlets are produced from high pressure die-cast zinc alloy which is durable, strong and rust resistant. The unit is adjustable to suit the screed depth up to 90mm and with internal threads which will accept 25mm conduit nipple for mounting pedestal outlet boxes. EGA duct outlets come with die-cast zinc alloy plugs and screw markers.

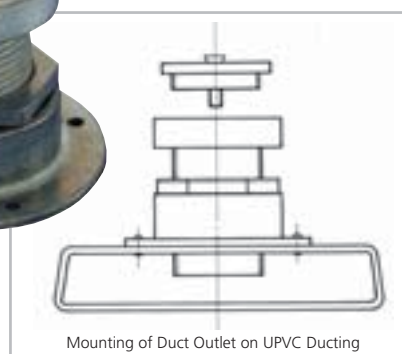

# Junction Box

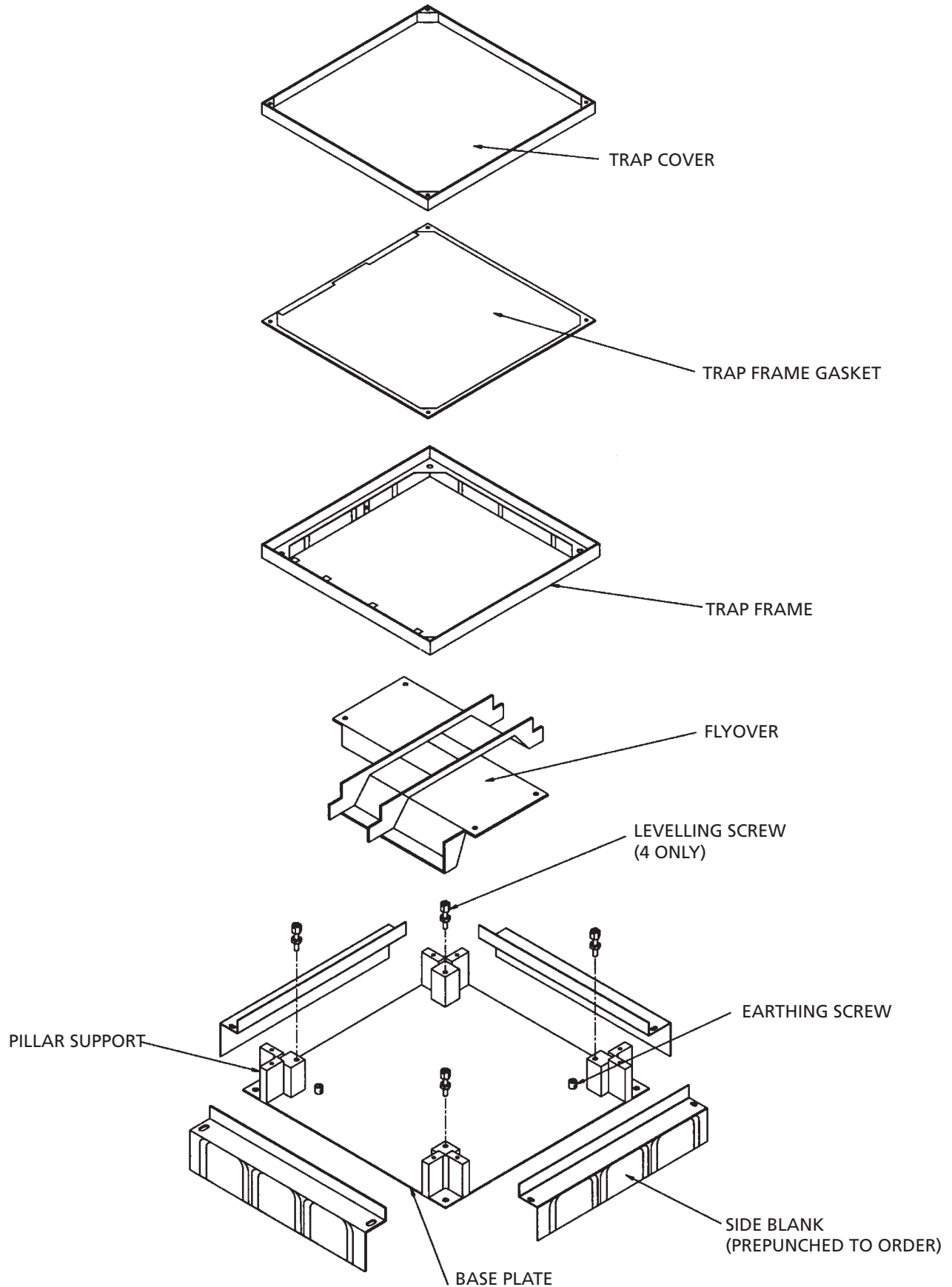

# Junction Box

- EGA underfloor junction box pillar supports, trap frames and traps covers are manufactured from high pressure zinc alloy die casting material for good mechanical strength and rust resistant.
- The base plate and side blanks are all made from pre-galvanised steel which has good protection against rust.
- The trap frame and trap cover are epoxy coated to give a good protection on the visible parts.
- The flyover is fabricated from ABS materials for plastic type and electro-galvanised steel with epoxy coating for the steel type.

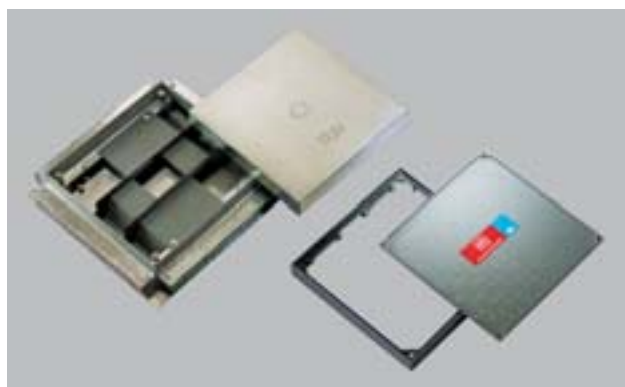

## Junction Box for Max. 25mm Depth Ductings

List No.	Description
LZJB 250/1	250 x 125 x 55 -70mm 1 Compartment Consist of LBBJ 250/1 & JBS 250/1
LZJB 250/2	250 x 250 x 55 -70mm 2 Compartments Consist of LBBJ 250/2 & JBS 250/2
LZJB 250/3	250 x 250 x 55 -70mm 3 Compartments Consist of LBBJ 250/3 & JBS 250/3
LZJB 300/2	300 x 300 x 55 -70mm 2 Compartments Consist of LBBJ 300/2 & JBS 300/2
LZJB 300/3	300 x 300 x 55 -70mm 3 Compartments Consist of LBBJ 300/3 & JBS 300/3
LZJB 375/3	375 x 250 x 55 -70mm 3 Compartments Consist of LBBJ 375/3 & JBS 375/3
LZJB 375/S/3	375 x 375 x 55 -70mm 3 Compartments Consist of LBBJ 375S/3 & JBS 375S/3

## Junction Box for Max. 32mm Depth Ductings

List No.	Description
LHJB 250/1	250 x 125 x 75 -90mm 1 Compartment Consist of LHBJ 250/1 & JBS 250/1
LHJB 250/2	250 x 250 x 75 -90mm 2 Compartments Consist of LHBJ 250/2 & JBS 250/2
LHJB 250/3	250 x 250 x 75 -90mm 3 Compartments Consist of LHBJ 250/3 & JBS 250/3
LHJB 300/2	300 x 300 x 75 -90mm 2 Compartments Consist of LHBJ 300/2 & JBS 300/2
LHJB 300/3	300 x 300 x 75 -90mm 3 Compartments Consist of LHBJ 300/3 & JBS 300/3
LHJB 375/3	375 x 250 x 75 -90mm 3 Compartments Consist of LHBJ 375/3 & JBS 375/3
LHJB 375/S/3	375 x 375 x 75 -90mm 3 Compartments Consist of LHBJ 375S/3 & JBS 375S/3

## Junction Box for Max. 38mm Depth Ductings

List No.	Description
LXJB 250/1	250 x 125 x 75mm -90mm 1 Compartment Consist of LXBJ 250/1 & JBS 250/1
LXJB 250/2	250 x 250 x 75mm -90mm 2 Compartments Consist of LXBJ 250/2 & JBS 250/2
LXJB 250/3	250 x 250 x 75mm -90mm 3 Compartments Consist of LXBJ 250/3 & JBS 250/3
LXJB 300/2	300 x 300 x 75mm -90mm 2 Compartments Consist of LXBJ 300/2 & JBS 300/2
LXJB 300/3	300 x 300 x 75mm -90mm 3 Compartments Consist of LXBJ 300/3 & JBS 300/3
LXJB 375/3	375 x 250 x 75mm -90mm 3 Compartments Consist of LXBJ 375/3 & JBS 375/3
LXJB 375/S/3	375 x 375 x 75mm -90mm 3 Compartments Consist of LXBJ 375S/3 & JBS 375S/3

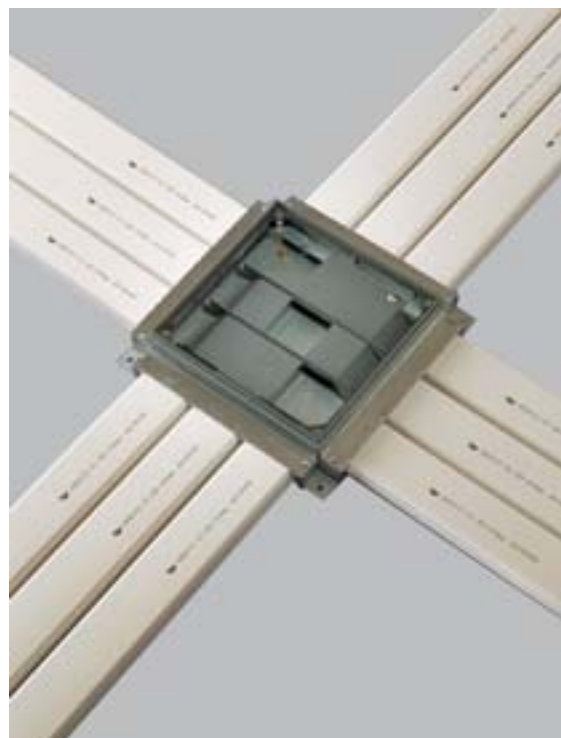

# Service Outlet Box

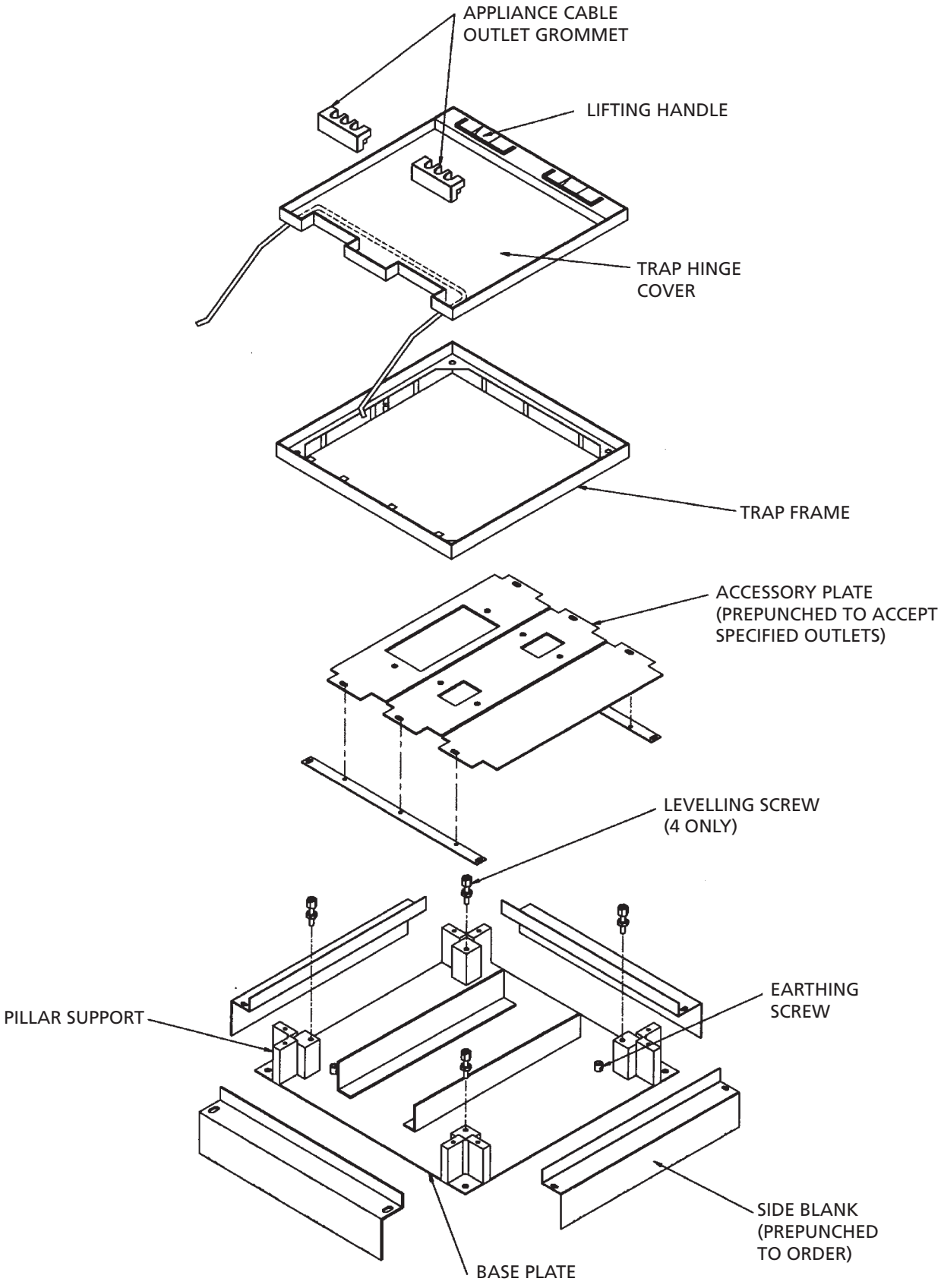

# Service Outlet Box

- EGA underfloor service outlet box pillar supports, the base plate and side blanks are all made from pre-galvanised steel which has good protection against rust.
- The trap frame and trap cover are epoxy coated to give a good protection on the visible parts.

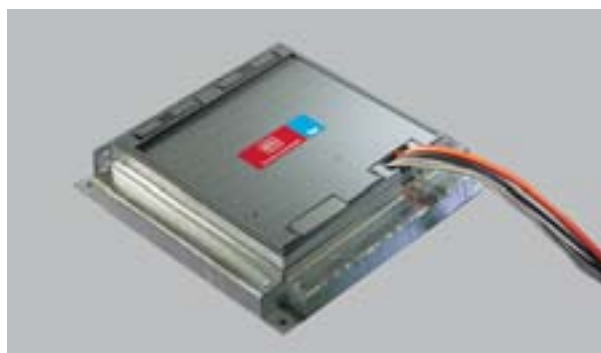

## Service Box for Max. 25mm Depth Ductings

List No.	Description
LZSB 125/1/1	125 x 125 x 55 -70mm 1 Compartment 1 Trap Consist of LBBS 125/1 & SBS 125/1/1
LZSB 125/2/2	250 x 125 x 55 -70mm 2 Compartments 2 Traps Consist of LBBS 250/1 & SBS 125/2/2
LZSB 250/1/1	250 x 125 x 55 -70mm 1 Compartment 1 Trap Consist of LBBS 250/1 & SBS 250/1/1
LZSB 250/2/1	250 x 250 x 55 -70mm 2 Compartments 1 Trap Consist of LBBS 250/2 & SBS 250/2/1
LZSB 250/2/2	250 x 250 x 55 -70mm 2 Compartments 2 Traps Consist of LBBS 250/2 & SBS 250/2/2
LZSB 250/3/1	250 x 250 x 55 -70mm 3 Compartments 1 Trap Consist of LBBS 250/3 & SBS 250/3/1
LZSB 300/2/1	300 x 300 x 55 -70mm 2 Compartments 1 Trap Consist of LBBS 300/2 & SBS 300/2/1
LZSB 300/3/1	300 x 300 x 55 -70mm 3 Compartments 1 Trap Consist of LBBS 300/3 & SBS 300/3/1
LZSB 375/3/2	375 x 250 x 55 -70mm 3 Compartments 2 Traps Consist of LBBS 375/3 & SBS 375/3/2
LZSB 375/3/3	375 x 250 x 55 -70mm 3 Compartments 3 Traps Consist of LBBS 375/3 & SBS 375/3/3

## Service Box for Max. 32mm Depth Ductings

List No.	Description
LHSB 125/1/1	125 x 125 x 75 -90mm 1 Compartment 1 Trap Consist of LHBS 125/1 & SBS 125/1/1
LHSB 125/2/2	250 x 125 x 75 -90mm 2 Compartments 2 Traps Consist of LHBS 250/1 & SBS 125/2/2
LHSB 250/1/1	250 x 125 x 75 -90mm 1 Compartment 1 Trap Consist of LHBS 250/1 & SBS 250/1/1
LHSB 250/2/1	250 x 250 x 75 -90mm 2 Compartments 1 Trap Consist of LHBS 250/2 & SBS 250/2/1
LHSB 250/2/2	250 x 250 x 75 -90mm 2 Compartments 2 Traps Consist of LHBS 250/2 & SBS 250/2/2
LHSB 250/3/1	250 x 250 x 75 -90mm 3 Compartments 1 Trap Consist of LHBS 250/3 & SBS 250/3/1
*LHSB 300/2/1	300 x 300 x 75 -90mm 2 Compartments 1 Trap Consist of LHBS 300/2 & SBS 300/2/1
*LHSB 300/3/1	300 x 300 x 75 -90mm 3 Compartments 1 Trap Consist of LHBS 300/3 & SBS 300/3/1
LHSB 375/3/2	375 x 250 x 75 -90mm 3 Compartments 2 Traps Consist of LHBS 375/3 & SBS 375/3/2
LHSB 375/3/3	375 x 250 x 75 -90mm 3 Compartments 3 Traps Consist of LHBS 375/3 & SBS 375/3/3

\* 12mm recess cover for ceramic tile is available.

## Service Box for Max. 38mm Depth Ductings

List No.	Description
LXSB 125/1/1	125 x 125 x 75 -90mm 1 Compartment 1 Trap Consist of LXBS 125/1 & SBS 125/1/1
LXSB 125/2/2	250 x 125 x 75 -90mm 2 Compartments 2 Traps Consist of LXBS 250/1 & SBS 125/2/2
LXSB 250/1/1	250 x 125 x 75 -90mm 1 Compartment 1 Trap Consist of LXBS 250/1 & SBS 250/1/1
LXSB 250/2/1	250 x 250 x 75 -90mm 2 Compartments 1 Trap Consist of LXBS 250/2 & SBS 250/2/1
LXSB 250/2/2	250 x 250 x 75 -90mm 2 Compartments 2 Traps Consist of LXBS 250/2 & SBS 250/2/2
LXSB 250/3/1	250 x 250 x 75 -90mm 3 Compartments 1 Trap Consist of LXBS 250/3 & SBS 250/3/1
*LXSB 300/2/1	300 x 300 x 75 -90mm 2 Compartments 1 Trap Consist of LXBS 300/2 & SBS 300/2/1
*LXSB 300/3/1	300 x 300 x 75 -90mm 3 Compartments 1 Trap Consist of LXBS 300/3 & SBS 300/3/1
LXSB 375/3/2	375 x 250 x 75 -90mm 3 Compartments 2 Traps Consist of LXBS 375/3 & SBS 375/3/2
LXSB 375/3/3	375 x 250 x 75 -90mm 3 Compartments 3 Traps Consist of LXBS 375/3 & SBS 375/3/3

# Service Outlet Box Accessories

## Floor Boxes

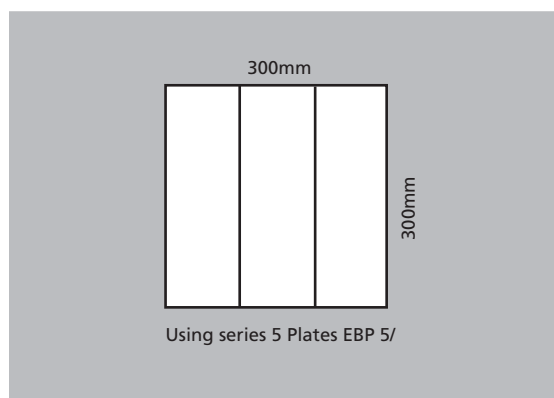
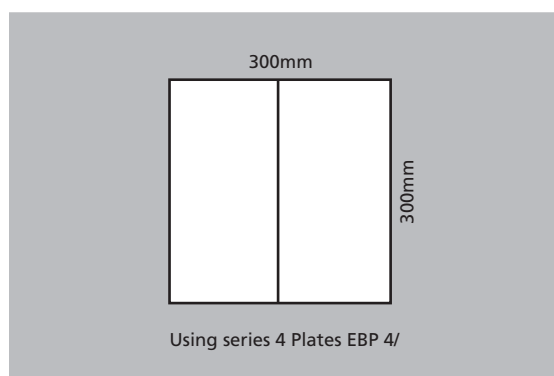
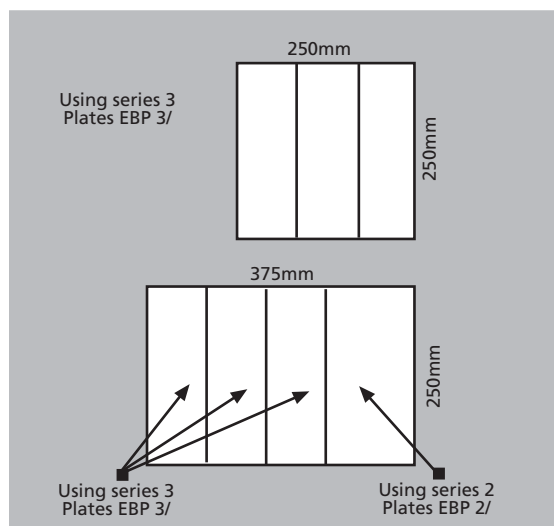
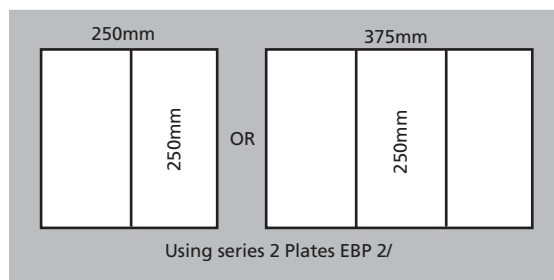
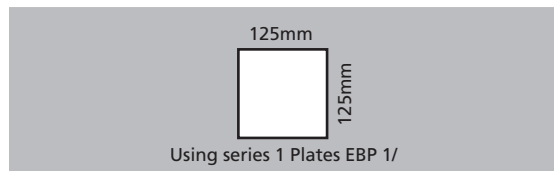

### Accessory description and list No

#### BLANK PLATES

Blank plate for use with LZSB 125/1/1

Blank plate for use with LZSB 250/2/1 or LZSB 375/2/2 or LZSB 375/3/3

Blank plate for use with LZSB 250/3/1

Blank plate for use with LZSB 300/2/1

Blank plate for use with LZSB 300/3/1

#### PLATES FOR 13A POWER ACCESSORIES

For one 2531 WHI (1 gang Panel Mounting 13A Switchsocket)

For two 2531 WHI (1 gang Panel Mounting 13A Switchsocket)

For one 2532 WHI (2 gang Panel Mounting 13A Switchsocket)

For one 1 gang LOGIC accessory

For two 1 gang LOGIC accessories

For one 2939 WHI (2 gang MINILOGIC 13A Switchsocket)

#### COMBINATION PLATES FOR 13A POWER WITH TELECOM ACCESSORIES

For one MK 2531 WHI (1 gang Panel Mounting 13A Switchsocket) and one 2917 WHI (1 gang MINILOGIC American Telephone Socket)

#### PLATES FOR TELECOM/DATA ACCESSORIES

For one 2917 WHI (1 gang MINILOGIC Telephone Socket American Type)

For two 2917 WHI (1 gang MINILOGIC Telephone Socket American Type)

For one GX5453 WHI & GX5454 WHI (1 gang MINILOGIC Data Computer Outlet)

Cutout for American Type Face Plate

FOR 125 X 125MM  
1 COMPARTMENT  
BOX

FOR 250 X 250MM  
2 COMPARTMENT  
BOXES OR  
375 X 250MM  
3 COMPARTMENTS  
BOXES

FOR 250 X 250MM  
3 COMPARTMENT  
BOXES OR  
375 X 250MM  
4 COMPARTMENT  
BOXES

FOR 300 X 300MM  
2 COMPARTMENT  
BOXES

FOR 300 X 300MM  
3 COMPARTMENT  
BOXES

*Series 1 Plate List No.*   *Series 2 Plate List No.*   *Series 3 Plate List No.*   *Series 4 Plate List No.*   *Series 5 Plate List No.*

EBP 1/01

EBP 2/01

EBP 3/01

EBP 4/01

EBP 5/01

EBP 1/02

EBP 2/02

EBP 3/02

EBP 4/02

EBP 5/02

EBP 2/21

EBP 3/27

EBP 4/21

EBP 5/27

EBP 2/03

EBP 3/03

EBP 4/03

EBP 5/03

EBP 1/03

EBP 2/04

EBP 4/04

EBP 5/43

EBP 2/14

EBP 3/41

EBP 4/14

EBP 5/41

EBP 2/42R

EBP 3/05R

EBP 5/05R

EBP 2/24

EBP 3/34

EBP 4/24

EBP 5/34

EBP 1/05

EBP 2/07

EBP 3/04

EBP 4/07

EBP 5/04

EBP 2/08

EBP 3/08

EBP 4/08

EBP 5/08

EBP 2/73 ACC

EBP 3/73 ACC

EBP 5/73 ACC

EBP 2/65

EBP 3/65

EBP 5/60

# Vertical Access Boxes & Pedestal Outlet Boxes

The vertical access box helps to facilitate easy accessibility from floor ducts to wall ducts. This is for connections to distribution boards or other floors.



## Vertical Access Box for Max. 25mm Depth Ductings

List No.	Description
LVB 125/1 or EVB 125/1	125 x 200 x 50mm 1 compartment
LVB 250/2 or EVB 250/2	250 x 200 x 50mm 2 compartments
LVB 250/3 or EVB 250/3	250 x 200 x 50mm 3 compartments
LVB 300/2 or EVB 300/2	300 x 200 x 50mm 2 compartments
LVB 300/3 or EVB 300/3	300 x 200 x 50mm 3 compartments
LVB 375/3 or EVB 375/3	375 x 200 x 50mm 3 compartments
LVB 400/3 or EVB 400/3	400 x 200 x 50mm 3 compartments

## Vertical Access Box for Max. 32mm Depth Ductings

List No.	Description
EHVB 125/1	125 x 250 x 50mm 1 compartment
EHVB 250/2	250 x 250 x 50mm 2 compartments
EHVB 250/3	250 x 250 x 50mm 3 compartments
EHVB 300/2	300 x 250 x 50mm 2 compartments
EHVB 300/3	300 x 250 x 50mm 3 compartments
EHVB 375/3	375 x 250 x 50mm 3 compartments
EHVB 400/3	400 x 250 x 50mm 3 compartments

## Vertical Access Box for Max. 38mm Depth Ductings

List No.	Description
EXVB 125/1	125 x 250 x 50mm 1 compartment
EXVB 250/2	250 x 250 x 50mm 2 compartments
EXVB 250/3	250 x 250 x 50mm 3 compartments
EXVB 300/2	300 x 250 x 50mm 2 compartments
EXVB 300/3	300 x 250 x 50mm 3 compartments
EXVB 375/3	375 x 250 x 50mm 3 compartments
EXVB 400/3	400 x 250 x 50mm 3 compartments

## Pedestal Outlet Boxes

In locations where concealed service boxes are not available, pedestal boxes can be mounted to accommodate power, telephone or computer sockets. EGA pedestal boxes are produced from high pressure cast alloy which is strong and resistant to rust, or electro-galvanized steel with epoxy coating.

List No.	Description
EPO 1	For single gang socket
EPO 2	For two gang sockets



# Specifier's Guide

## Ega Underfloor Ducting System

### GENERAL

The Underfloor Ducting System suitable for the distribution of telephone, power and computer services within floor screed shall be provided in accordance with the layouts as show on the specification drawings. The system shall comprise single or multi-way extruded trapezoidal form ducts made of rigid, non-corrodible, heave gauge uPVC (unplasticised polyvinyl chloride) with minimum wall thickness of 2.5mm for 50mm width and 3.2mm thickness for 75mm width and above. To form the whole system, rectangular shape, pre-galvanised steel metal ducts with minimum sheet thickness of 1.6mm must be used. Junction boxes, service outlets, duct outlets and pedestal outlet boxes shall be fabricated from high tensile strength, pressure die cast zinc alloy material. Accessories shall consist of mounting plates, vertical access boxes, jointing sleeves, fixing clips and flyovers. The system shall be proprietary made similar to "EGA Underfloor Ducting System" manufactured by MK Electric.

The power cable for power socket outlets should not be drawn into the same single compartment duct as the telephone cables or computer cables for computer services. Multi-compartments ducting and junction boxes with flyovers (cross-over bridges) shall be provided to ensure segregation of these three services.

The system shall comprise of the following components:

#### 1. Junction Boxes and Service Outlet Boxes

The junction boxes and service outlet boxes pillar supports shall be constructed from high tensile strength, zinc alloy materials. It should be riveted onto a 1.2mm thick pre-galvanised steel base plate. An earth wire connector must be provided for all the boxes.

#### 2. Trap Frames and Covers

The trap frames and covers shall be constructed from high tensile strength, pressure injection zinc alloy die cast material. It should be further protected by an electrostatically coated high temperature oven baked epoxy powder coating to protect all visible parts from stains as well as to add aesthetics to the units. Covers for junction boxes shall be secured by countersunk nickel plated brass screws and designed with 6mm recess to receive vinyl tiles or carpets. Covers for service outlet boxes shall be provided with suitable hinges designed to open through 180 degrees, giving access always to the power, telephone and data outlets. It should have a 6mm recess to receive vinyl tiles or carpets. A casting cover (disposable screeding lid) shall be provided to keep the actual cover clean and undamaged during installation. All boxes shall be adjustable in height independently with hexagonal head nickel plated brass bolts for easy adjustment and to take account of difference in floor thickness. Adequate segregation shall be provided between service runs within junction boxes by using flyovers (cross over bridges). Cables emerging from service boxes shall be protected against damages by means of PVC cable exit grommets and shall be reversible to 'close' position when not in use. All covers must be provided with a stud for earth wire connection.

#### 3. uPVC Ductings

uPVC ducting shall be rigid and extruded from super high impact, heavy gauge uPVC (unplasticised polyvinyl chloride) into trapezoidal shape with height not more than 25mm and width of 50mm, 75mm or 100mm. The ducting wall thickness shall be 2.5mm, 3.2mm and 3.2mm respectively.

#### 4. Metal Ductings

Rectangular formed metal ductings shall be fabricated from 1.6mm thick pre-galvanised steel sheets. The top and bottom plates shall be double folded and spot welded together to the full height of the ductings to give the required rigidity and at the same time to prevent seepage of concrete or screed water. Metal jointing sleeves with locking screws for grounding purpose must be provided.

#### 5. Duct Outlets (Pedestal Connections)

Duct outlets as detailed on the drawing shall be provided. This pedestal connection shall be manufactured from high tensile strength, pressure injection zinc alloy die cast material. It must be designed for easy installation, rigidity and mechanical strength. The duct outlets shall be supplied with adjustable screw studs for easy adjustment and levelling to suit the required finished floor level.

#### 6. Pedestal Outlet Boxes

The pedestal outlet boxes shall be manufactured from high tensile strength, pressure injection zinc alloy die-cast material and fitted with an earth wire connector. The unit must be easy for installation onto the duct outlet. The pedestal outlet boxes must be stain-proof with a high temperature, oven baked epoxy powder coating with the required colour to suit the surrounding colour scheme or architect's choice.

# Installation Guide

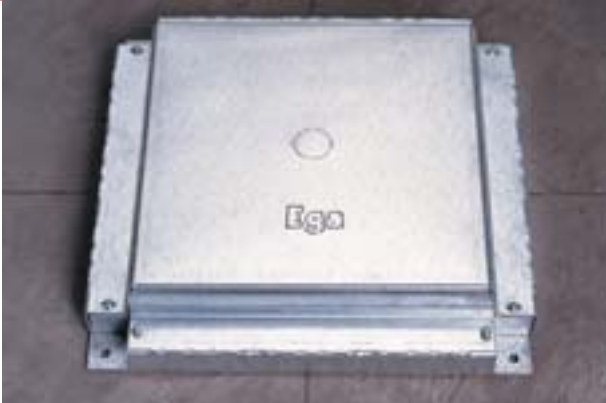

1. Determine floor box location and then fasten with bolts and nuts



2. Peel off the pre-punched knock-outs at the side blank plate before laying the ductings



3. Fasten the side blank plate



4. Use steel fixing clips to secure the ductings



5. The Underfloor Ducting System ready for screeding



6. After screeding has cured



7. Use hammer to knock and loosen the disposable lid before hooking it out

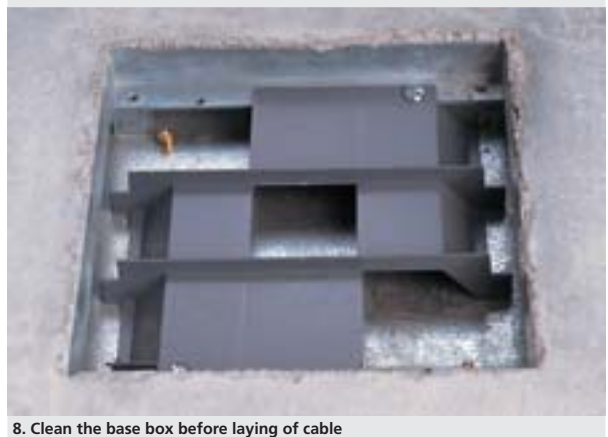

8. Clean the base box before laying of cable



9. To adjust the 4 leveling screws to meet the finished level



13. Install accessory plates

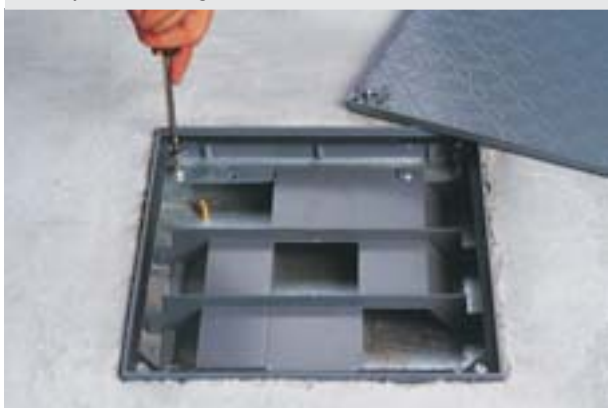

10. Mount the trap frame (Junction Box)



14. Mount trap frames



11. Mount the trap cover (Junction Box)



15. Mount trap cover

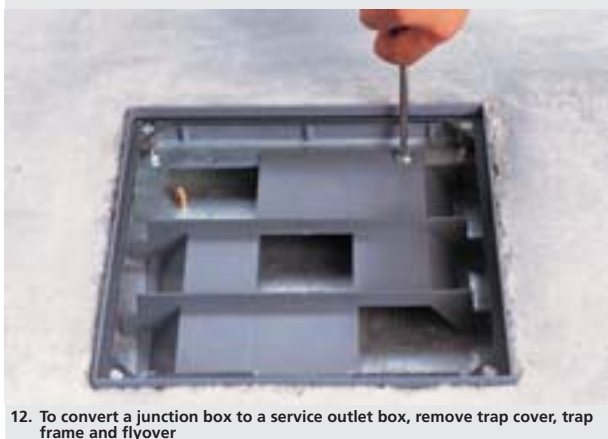

12. To convert a junction box to a service outlet box, remove trap cover, trap frame and flyover

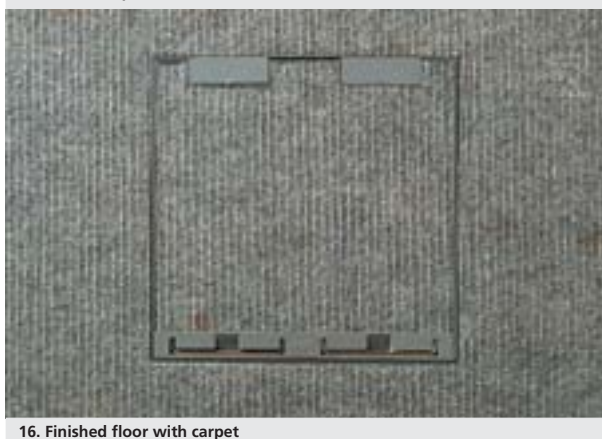

16. Finished floor with carpet



### MK Electric (Singapore)

MK Electric (Singapore) 8 Pandan Crescent, UE Tech Park #01-06 (LL4), Singapore 128464	Telephone : (65) 6461 6333	Facsimile : (65) 6461 6336 / (65) 6461 6338
MK Electric (Malaysia) Sdn Bhd Jalan Pengapit 15/19, 40000 Shah Alam Selangor Darul Ehsan, Malaysia	Telephone : (60) 03 5519 2549	Facsimile : (60) 03 5510 8867
MK Electric (China) 15/F, Tower5, China Hong Kong City, Tsimshatsui, Hong Kong	Telephone : (852) 2834 1988	Facsimile : (852) 2834 0012
PT. MK Electric (Indonesia) Mangga Dua Harco Blok E25, Floor 4 Jakarta 10730	Telephone : (62) 021 625 6204	Facsimile : (62) 021 612 1987
Website <a href="http://www.novarintl.com">www.novarintl.com</a>	Publication No: EGA 01N 0704	

